



(19) **United States**

(12) **Patent Application Publication**
Lee

(10) **Pub. No.: US 2008/0186264 A1**

(43) **Pub. Date: Aug. 7, 2008**

(54) **ORGANIC LIGHT EMITTING DISPLAY
DEVICE AND DRIVING METHOD THEREOF**

(52) **U.S. Cl. 345/82**

(76) Inventor: **Wook Lee, Suwon (KR)**

(57) **ABSTRACT**

Correspondence Address:
CHRISTIE, PARKER & HALE, LLP
PO BOX 7068
PASADENA, CA 91109-7068

An organic light emitting display device includes: a display area including a plurality of pixels coupled to scan, light emission control, and data lines; a scan driver electrically coupled to the display area through the scan lines and the light emission control lines; a data driver electrically coupled to the display area through the data lines; an optical sensor for generating an optical sensor signal corresponding to a brightness of an ambient light; a first luminance control unit for outputting a first luminance control signal for controlling a gamma-corrected gray level voltage of a data signal in accordance with the optical sensor signal, and a second luminance control unit for outputting a second luminance control signal for controlling a width of a light emission control signal in accordance with data of one frame of an image. The first luminance control unit turns the second luminance control unit on and off.

(21) Appl. No.: **11/861,128**

(22) Filed: **Sep. 25, 2007**

(30) **Foreign Application Priority Data**

Feb. 5, 2007 (KR) 10-2007-0011785

Publication Classification

(51) **Int. Cl.**
G09G 3/32 (2006.01)

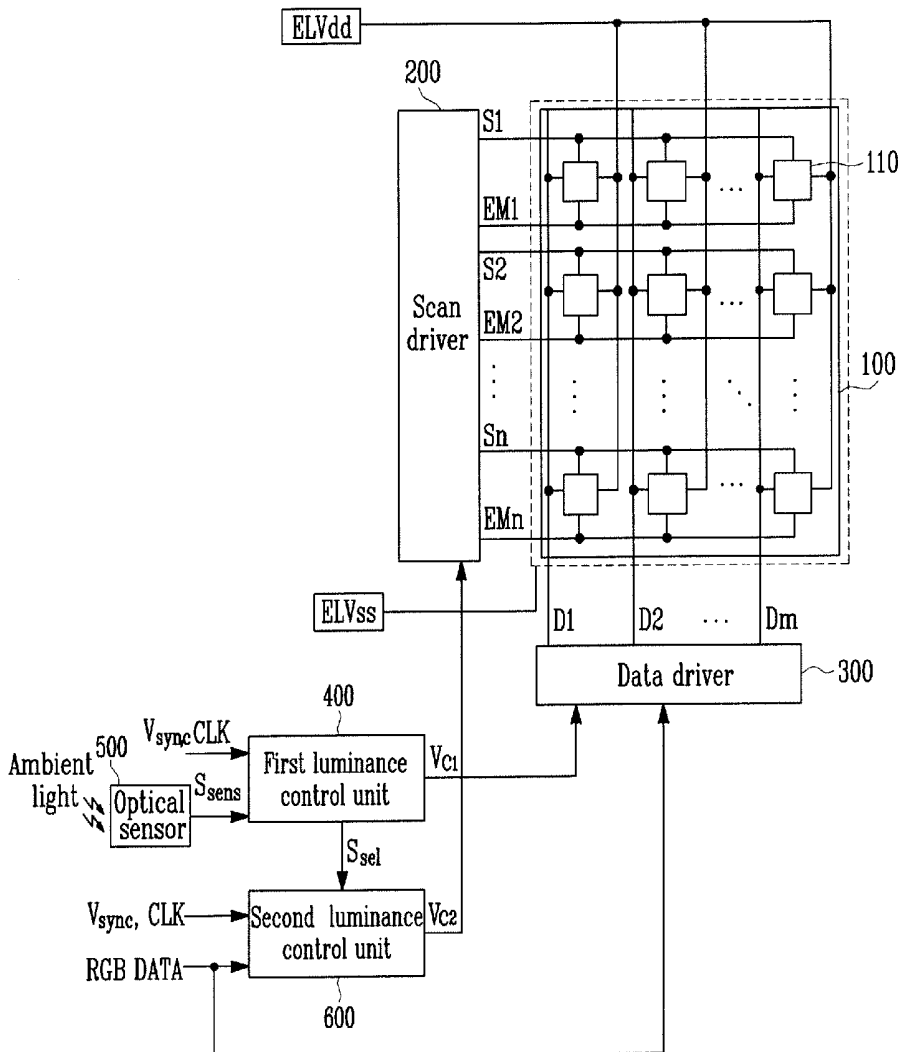

FIG. 1

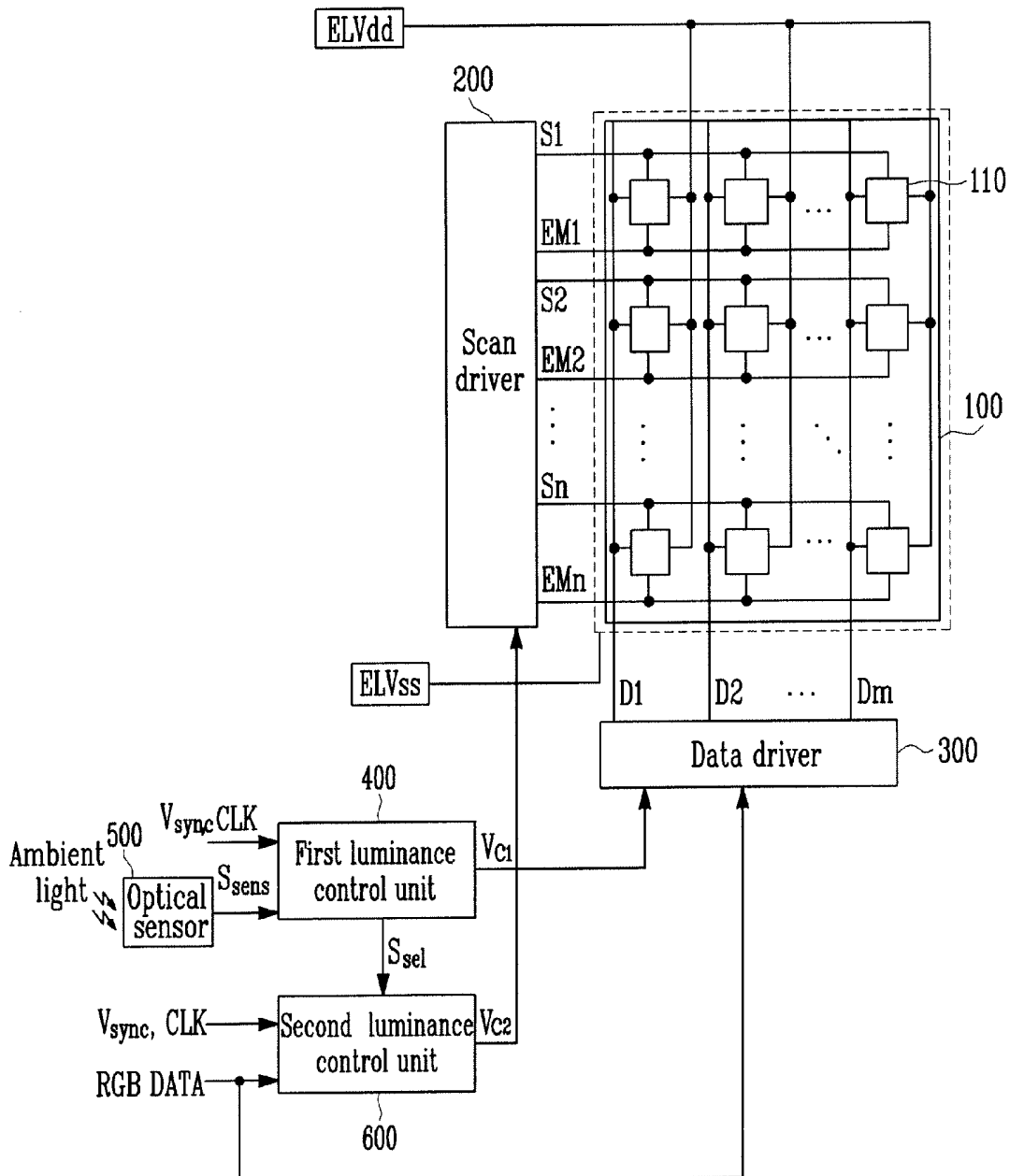

FIG. 2

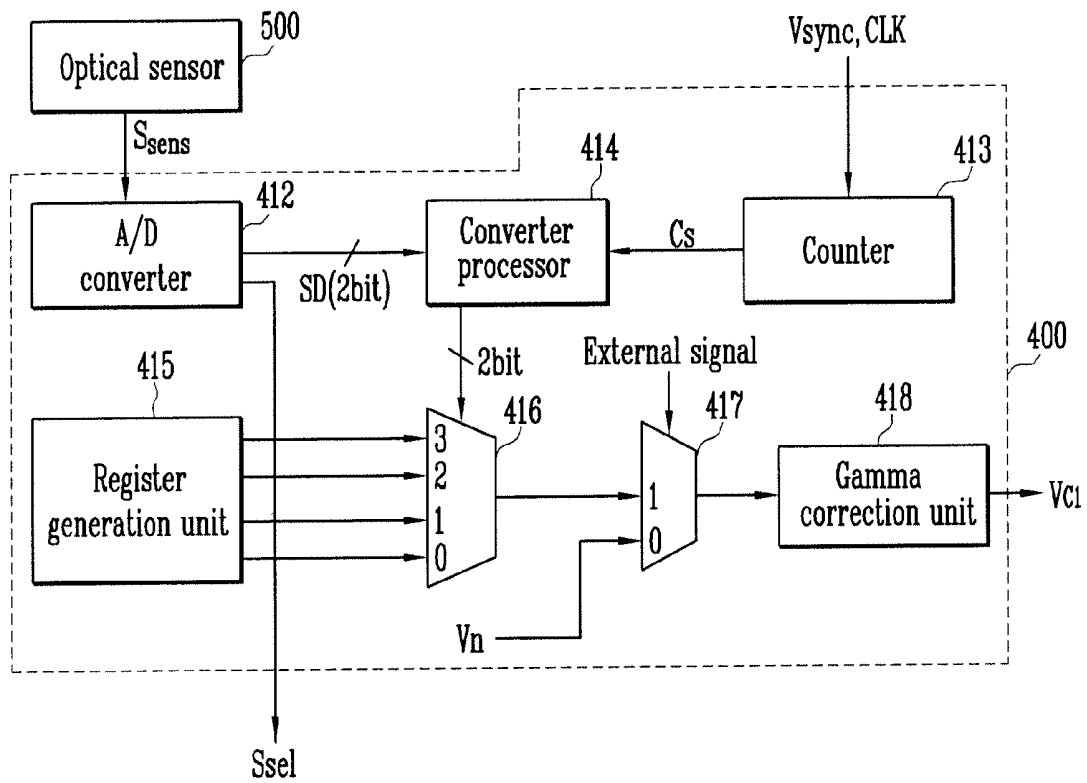

FIG. 3

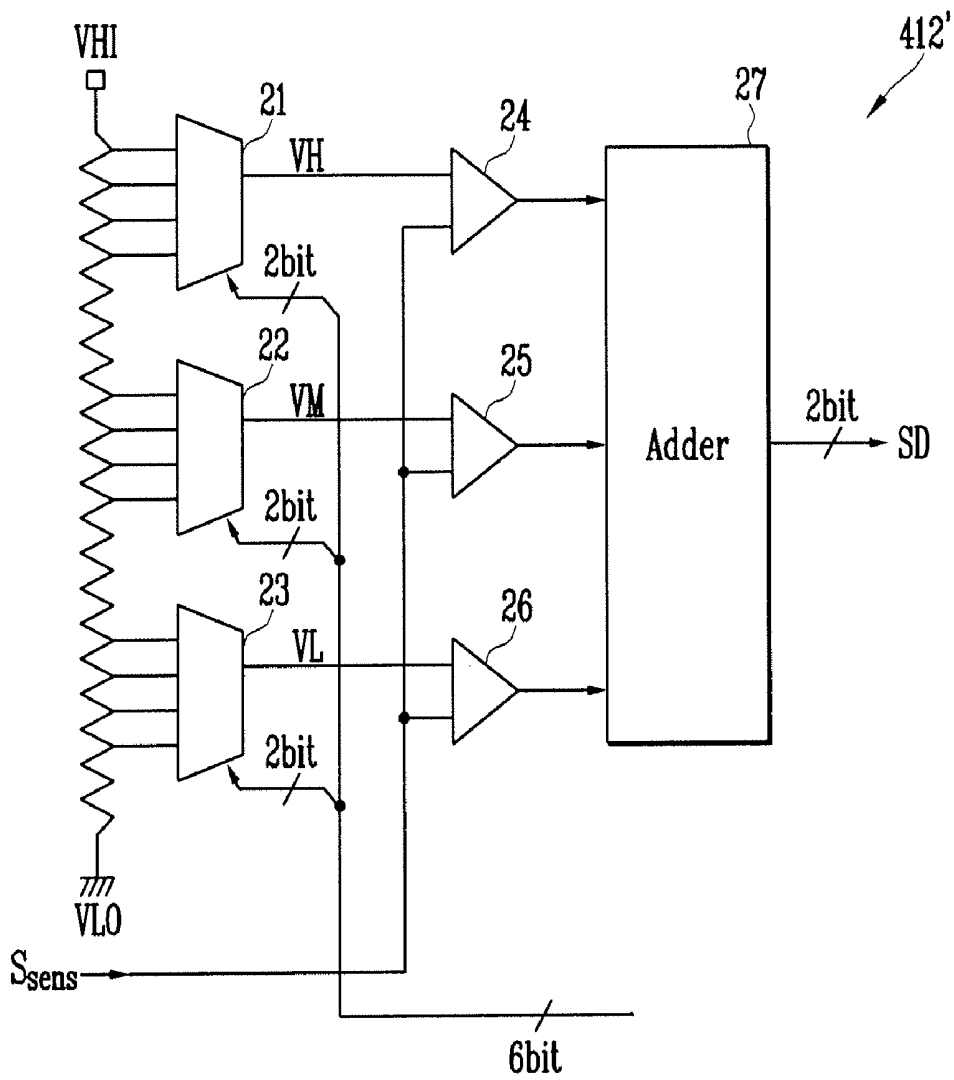

FIG. 4

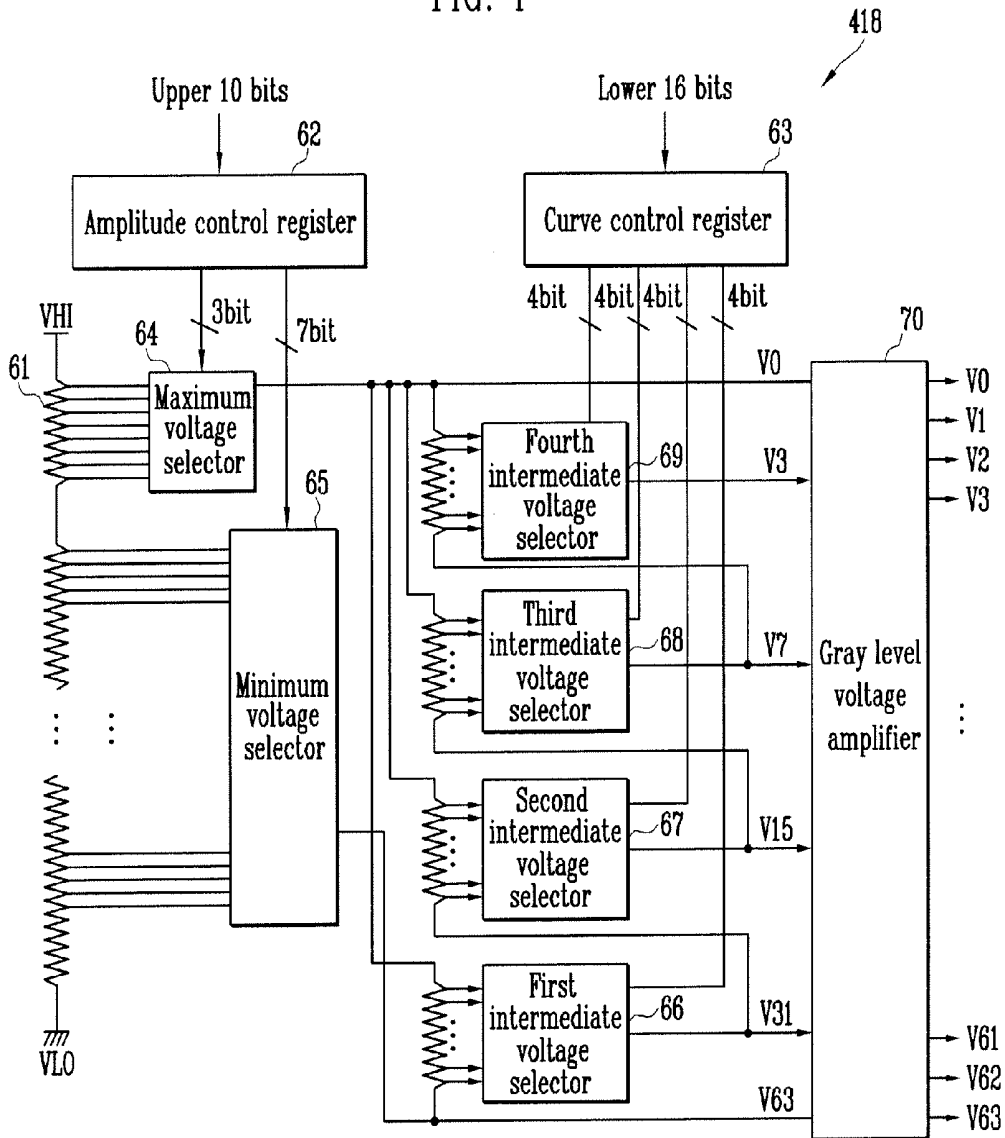

FIG. 5A

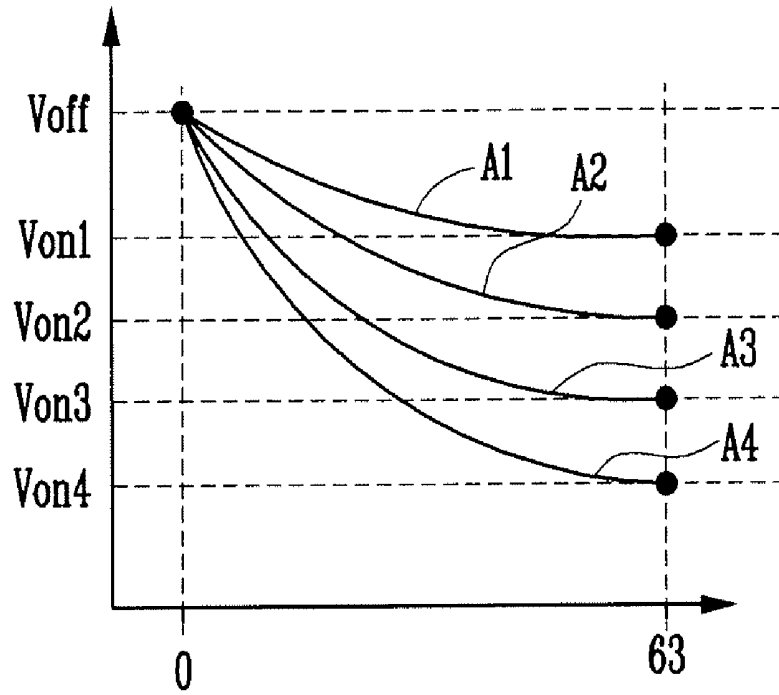

FIG. 5B

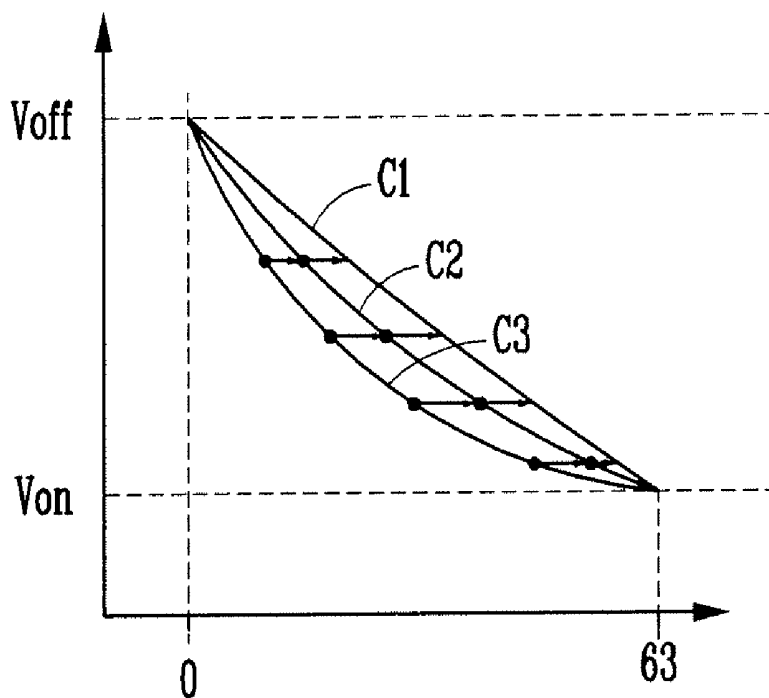

FIG. 6

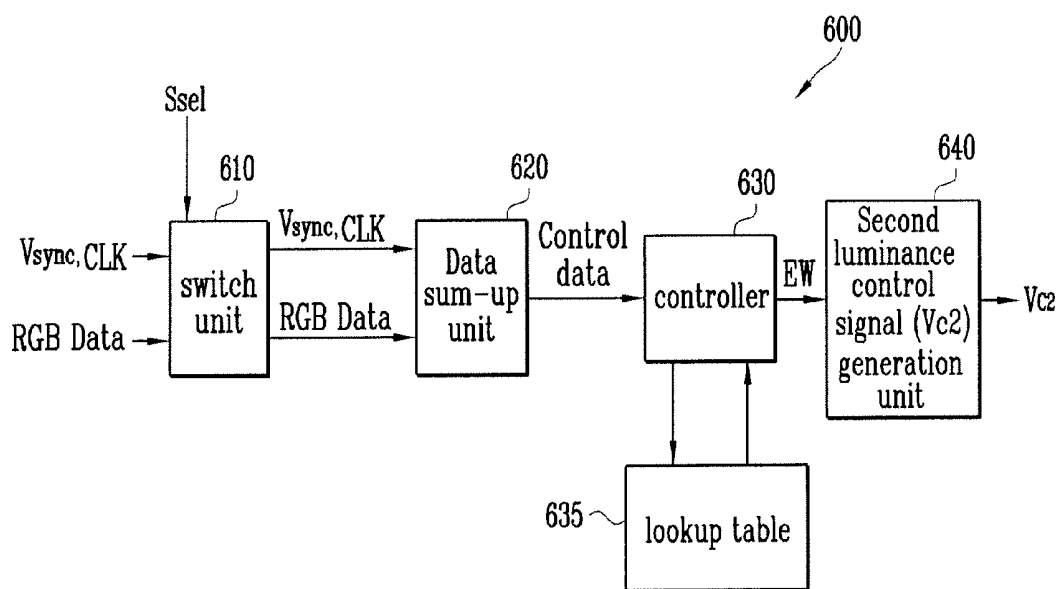

FIG. 7

635

Upper 5-bit value (Control data)	Light emitting rate	Light emitting ratio	luminance	EW(Hsync)
0	0%	100%	300	325
1	4%	100%	300	325
2	7%	100%	300	325
3	11%	100%	300	325
4	14%	100%	300	325
5	18%	99%	298	322
6	22%	98%	295	320
7	25%	95%	285	309
8	29%	92%	275	298
9	33%	88%	263	284
10	36%	83%	250	271
11	40%	79%	237	257
12	43%	75%	224	243
13	47%	70%	209	226
14	51%	64%	193	209
15	54%	61%	182	197
16	58%	57%	170	184
17	61%	53%	160	173
18	65%	50%	150	163
19	69%	48%	143	155
20	72%	45%	136	147
21	76%	43%	130	141
22	79%	41%	124	134
23	83%	40%	119	128
24	87%	38%	113	122
25	90%	36%	109	118
26	94%	35%	104	113
27	98%	34%	101	109
28	—	—	—	—
29	—	—	—	—
30	—	—	—	—
31	—	—	—	—

ORGANIC LIGHT EMITTING DISPLAY DEVICE AND DRIVING METHOD THEREOF

CROSS-REFERENCE TO RELATED APPLICATIONS

[0001] This application claims priority to and the benefit of Korean Patent Application No. 10-2007-0011785, filed on Feb. 5, 2007, in the Korean Intellectual Property Office, the entire content of which is incorporated herein by reference.

BACKGROUND

[0002] 1. Field of the Invention

[0003] The present invention relates to an organic light emitting display device and a driving method thereof.

[0004] 2. Discussion of Related Art

[0005] In recent years, various flat panel displays, which have reduced weight and volume compared to cathode ray tubes, have been developed. In particular, organic light emitting diode display devices have attracted public attention, because the organic light emitting diode display devices have an excellent luminance and color purity since organic compounds are used as a light emission material.

[0006] Such an organic light emitting display device is expected to be effectively used for portable display devices, and the like, since it is thin and light-weight and may be driven at a low electric power.

[0007] However, conventional organic light emitting display devices emit light with a constant luminance regardless of surrounding brightness, and therefore their visibility is varied according to the surrounding brightness even if an image is displayed with the same gray levels. For example, an image, which is displayed when the surrounding brightness is high, has a reduced visibility, compared to an image displayed when the surrounding brightness is low.

[0008] Also, in conventional organic light emitting display devices, the amount of electric current that flows to a display area increases as the number of pixels that emit light during one frame period increases. Further, if there are pixels among the light-emitting pixels, that display high gray levels, a larger amount of electric current flows to the display area, resulting in increased power consumption.

SUMMARY OF THE INVENTION

[0009] Accordingly, one exemplary embodiment of the present invention is an organic light emitting display device capable of controlling a luminance according to brightness of the ambient light and data of one frame, reducing power consumption, and also preventing excessive reduction of luminance, and a driving method thereof.

[0010] An aspect of an exemplary embodiment of the present invention is an organic light emitting display device for displaying an image. The organic light emitting display has a plurality of scan lines, a plurality of light emission control lines and a plurality of data lines, and includes a display area including a plurality of pixels coupled to the scan lines, the light emission control lines and the data lines; a scan driver electrically coupled to the display area through the scan lines and the light emission control lines; a data driver electrically coupled to the display area through the data lines; an optical sensor for generating an optical sensor signal corresponding to a brightness of an ambient light; a first luminance control unit for outputting a first luminance control signal for controlling a gamma-corrected gray level voltage of a data

signal of the image, applied to the data lines, in accordance with the optical sensor signal; and a second luminance control unit for outputting a second luminance control signal for controlling a width of a light emission control signal applied to the light emission control lines, in accordance with data of one frame of the image. The first luminance control unit is adapted to control the second luminance control unit to be turned on and off.

[0011] The first luminance control unit may be further adapted to generate a selection signal for controlling on and off of the second luminance control unit in accordance with the optical sensor signal. The selection signal may turn off the second luminance control unit in accordance with the optical sensor signal corresponding to at least one brightness level including a darkest brightness level of the ambient light. The first luminance control unit may include an analog/digital converter for converting the optical sensor signal, which is an analog signal, to a digital sensor signal; a counter for counting pulses to generate a counting signal during one frame period; a converter processor for outputting a control signal corresponding to the digital sensor signal and the counting signal; a register generation unit for dividing the brightness of the ambient light into a plurality of brightness levels and storing a plurality of register set values corresponding to the brightness levels; a selection unit for selecting one register set value corresponding to the control signal outputted by the converter processor, among the plurality of the register set values stored in the register generation unit, and outputting the selected one register set value; and a gamma correction unit for generating the first luminance control signal, which is a gamma correction signal, corresponding to the selected one register set value supplied by the selection unit. The analog/digital converter may be adapted to generate a selection signal for controlling on and off of the second luminance control unit in accordance with the optical sensor signal. The gamma correction signal may be set to increasingly reduce a luminance of the display area as the brightness of the ambient light decreases. The second luminance control unit may include a data sum-up unit for summing up the data of one frame to generate sum-up data and generating control data having at least two bit values including most significant bits of the sum-up data; a lookup table for storing a width information of the light emission control signal corresponding to the control data; a controller for extracting the width information of the light emission control signal corresponding to the control data from the lookup table; and a luminance control signal generation unit for generating the second luminance control signal corresponding to the width information of the light emission control signal supplied by the controller. The width of the light emission control signal may be set so that a luminance of the display area is decreased as a value of the control data increases. The second luminance control unit may further include a switch unit for selectively providing the data of one frame to the data sum-up unit in accordance with a selection signal supplied by the first luminance control unit.

[0012] Another aspect of an exemplary embodiment according to the present invention is a method for driving an organic light emitting display device having a display area including a plurality of pixels coupled to a plurality of scan lines, a plurality of light emission control lines and a plurality of data lines. The method includes: generating an optical sensor signal corresponding to a brightness of an ambient light; generating a luminance control signal for controlling a gamma-corrected gray level voltage of a data signal of the

image, applied to the data lines, in accordance with the optical sensor signal; controlling a luminance of the display area by using the data signal in accordance with the luminance control signal; and generating a selection signal in accordance with the optical sensor signal.

[0013] Said generating a luminance control signal may include: converting the optical sensor signal to a digital sensor signal; counting pulses to generate a counting signal during one frame period; outputting a control signal in accordance with the digital sensor signal and the counting signal; selecting one register set value corresponding to the control signal among the previously set register set values and outputting the selected register set value; and generating the luminance control signal corresponding to the one register set value. The method for driving an organic light emitting display device may further include controlling a width of a light emission control signal applied to the light emission control lines, in accordance with the selection signal. Said controlling a width of the light emission control signal may include: generating sum-up data obtained by adding up the data of one frame in accordance with the selection signal; and generating a second luminance control signal for controlling the width of the light emission control signal in accordance with the sum-up data.

BRIEF DESCRIPTION OF THE DRAWINGS

[0014] These and/or other aspects and features of the invention will become apparent and more readily appreciated from the following description of the exemplary embodiments, taken in conjunction with the accompanying drawings of which:

[0015] FIG. 1 is a block diagram showing a configuration of an organic light emitting display device according to one exemplary embodiment of the present invention.

[0016] FIG. 2 is a block diagram showing one exemplary embodiment of a first luminance control unit shown in FIG. 1.

[0017] FIG. 3 is a block diagram showing one exemplary embodiment of an A/D converter, which has some of the same functions as the A/D converter shown in FIG. 2.

[0018] FIG. 4 is a block diagram showing one exemplary embodiment of a gamma correction unit shown in FIG. 2.

[0019] FIG. 5A and FIG. 5B are graphs showing a gamma curve according to the gamma correction unit shown in FIG. 4.

[0020] FIG. 6 is a block diagram showing one exemplary embodiment of a second luminance control unit shown in FIG. 1.

[0021] FIG. 7 is an exemplary embodiment of a table illustrating values of a lookup table shown in FIG. 6.

DESCRIPTION OF MAJOR PARTS IN THE FIGURES

[0022]

100: display area	200: scan driver
300: data driver	400: first luminance control unit
500: optical sensor	600: second luminance control unit

DETAILED DESCRIPTION OF EMBODIMENTS

[0023] Hereinafter, exemplary embodiments according to the present invention will be described with reference to the accompanying drawings. Here, when one element is described as being connected to another element, one element may be not only directly connected to another element but instead may be indirectly connected to another element via one or more other elements. Further, some of the elements that are not essential to the complete understanding of the invention have been omitted for clarity. Also, like reference numerals refer to like elements throughout.

[0024] Exemplary embodiments according to the present invention provide an organic light emitting display device capable of controlling luminance according to a brightness of the ambient light and data of one frame. The embodiments of the present invention may result in reduced power consumption.

[0025] If the brightness of the ambient light and the luminance corresponding to data of one frame are both employed to reduce or limit a luminance of a display area, then the luminance of the display area may be excessively reduced, resulting in deteriorated visibility. Therefore, in an exemplary embodiment according to the present invention, when the brightness level of the ambient light is below a reference level (e.g., a predetermined or preset brightness level), the data of one frame is not used to further reduce or limit the luminance of the display area.

[0026] FIG. 1 is a block diagram showing a configuration of an organic light emitting display device according to one exemplary embodiment of the present invention.

[0027] Referring to FIG. 1, the organic light emitting display device according to one exemplary embodiment of the present invention includes a display area 100, a scan driver 200, a data driver 300, a first luminance control unit 400, an optical sensor 500 and a second luminance control unit 600.

[0028] The display area 100 includes a plurality of pixels 110 connected to scan lines (S1 to Sn), light emission control lines (EM1 to EMn) and data lines (D1 to Dm). Here, one pixel 110 has at least one organic light emitting diode and may be composed of at least two subpixels which emit the light having different colors, each subpixel having one organic light emitting diode having a corresponding color.

[0029] The display area 100 displays an image in accordance with a first power source (ELV_{dd}) and a second power source (ELV_{ss}) supplied from the outside, a scan signal and a light emission control signal supplied from the scan driver 200, and a data signal supplied from the data driver 300.

[0030] The scan driver 200 is electrically connected with the display area 100 through the scan lines (S1 to Sn) and the light emission control lines (EM1 to EMn). The scan driver 200 generates the scan signal and the light emission control signal. The scan signal generated in the scan driver 200 is sequentially supplied to each of the scan lines (S1 to Sn), and the light emission control signal is sequentially supplied to each of the light emission control lines (EM1 to EMn).

[0031] Here, a pulse width (or width) of the light emission control signal generated in the scan driver 200 is controlled by using a second luminance control signal (Vc2) when the second luminance control signal (Vc2) is supplied from the second luminance control unit 600. As described above, when the pulse width of the light emission control signal is controlled, a light emission time of the pixels 110 is varied, resulting in adjustment of the entire brightness of the display area 100.

[0032] The data driver 300 is electrically connected with the display area 100 through the data lines (D1 to Dm). The data driver 300 generates a data signal corresponding to image data (RGB Data) inputted therein and a gamma correction signal (a first luminance control signal (Vc1)) supplied from the first luminance control unit 400 during one frame period. The data signal generated in the data driver 300 is supplied to the data lines (D1 to Dm), and then supplied to each of the pixels 110 in synchronization with the scan signal.

[0033] Here, a gray level voltage of the data signal generated in the data driver 300 is controlled by the first luminance control signal (Vc1) corresponding to a brightness of the ambient light, and therefore the entire brightness of the display area 100 is adjusted according to the brightness of the ambient light.

[0034] The first luminance control unit 400 generates a first luminance control signal (Vc1) for controlling a gamma-corrected gray level voltage of the data signal in accordance with an optical sensor signal (Ssens) supplied from the optical sensor 500, and provides the generated first luminance control signal (Vc1) to the data driver 300.

[0035] More particularly, the first luminance control unit 400 selects a gamma value according to control signals supplied from the outside, such as the vertical synchronizing signal (Vsync) and the clock signal (CLK), and the optical sensor signal (Ssens) supplied from the optical sensor 500, and outputs the first luminance control signal (Vc1) which is a gamma correction signal corresponding to the selected gamma value.

[0036] Also, the first luminance control unit 400 further generates a selection signal (Ssel) for controlling ON/OFF of the second luminance control unit 600 in accordance with the optical sensor signal (Ssens) and supplies the generated selection signal (Ssel) to the second luminance control unit 600.

[0037] The first luminance control unit 400 outputs the first luminance control signal (Vc1) to increasingly reduce the luminance of the display area 100, as the optical sensor signal (Ssens) that corresponds to the increasingly darker brightness levels among the previously set levels of the brightness of the ambient light, is supplied to the first luminance control unit 400.

[0038] In one exemplary embodiment, the first luminance control unit 400 may also output the selection signal (Ssel) for controlling the second luminance control unit 600 to be turned off to prevent a maximally limited light emission from being further limited if the luminance of the display area 100 is maximally limited, for example, if the optical sensor signal (Ssens) corresponding to at least one brightness level including the darkest brightness level of the ambient light, is supplied.

[0039] The optical sensor 500 has an optical sensor element such as a phototransistor or photodiode to sense a brightness of an external light, namely, the ambient light, and generates the optical sensor signal (Ssens) corresponding to the brightness of the ambient light. The optical sensor signal (Ssens) generated in the optical sensor 500 is supplied to the first luminance control unit 400.

[0040] The second luminance control unit 600 generates a second luminance control signal (Vc2) for controlling a pulse width of the light emission control signal in accordance with data (RGB Data) of one frame, and provides the generated second luminance control signal (Vc2) to the scan driver 200.

[0041] In one exemplary embodiment, the second luminance control unit 600 generates the second luminance con-

trol signal (Vc2) corresponding to a sum-up value of the data (RGB Data) supplied therein during one frame period, and the synchronizing signal (Vsync) and clock signal (CLK).

[0042] The second luminance control unit 600 is controlled so that it can be turned on or off by using the first luminance control unit 400.

[0043] In one exemplary embodiment, the second luminance control unit 600 is set (or configured) so that it can be turned on/off by using the selection signal (Ssel) supplied from the first luminance control unit 400. For example, the second luminance control unit 600 may be set (or configured) so that it can output the second luminance control signal (Vc2) corresponding to a sum-up value of the data of one frame if the selection signal (Ssel) for directing "ON" is inputted into the second luminance control unit 600, and cannot be operated if the selection signal (Ssel) for directing "OFF" is inputted.

[0044] However, the second luminance control unit 600 may be set (or configured) to be turned on again if, for example, the optical sensor signal (Ssens) sensed in the optical sensor 500 is changed by more than a predetermined amount even after the second luminance control unit 600 is turned off by the selection signal (Ssel). As a result, the luminance of the display area 100 may be more effectively controlled by suitably reflecting (or using) the brightness of the ambient light and/or the luminance value corresponding to the data of one frame.

[0045] According to the above-mentioned organic light emitting display device in one embodiment of the present invention, the luminance of the display area 100 is controlled to correspond to the brightness of the ambient light and the data of one frame.

[0046] More particularly, the problem that visibility is varied according to the surrounding brightness can be solved by controlling a gamma-corrected gray level voltage of the data signal to control the luminance of the display area 100 in accordance with the brightness of the ambient light, and also a power consumption can be reduced by preventing the luminance of the display area 100 from being set to an excessively bright level. Also, an excessive electric current may be prevented from flowing to the display area 100 and a power consumption may be reduced by controlling the luminance of the display area 100 in accordance with the data of one frame and limiting the pulse width (or width) of the light emission control signal to control an amount of electric current flowing to the display area 100 if there are many pixels that display high gray levels during one frame period.

[0047] Also, the excessive reduction of luminance of the display area 100 may be prevented by configuring the first luminance control unit 400 to turn off the second luminance control unit 600 if the luminance of the display area 100 is maximally limited by the first luminance control unit 400. For example, if the brightness of the display area 100 is maximally limited by using the first luminance control signal (Vc1) generated in the first luminance control unit 400, then the excessive reduction in the luminance may be prevented in the darkest brightness level of the ambient light by turning off the second luminance control unit 600. In this case, it is possible to prevent unnecessary power consumption and the reduction to the safety margin for memory operation, caused by the operation of the second luminance control unit 600.

[0048] FIG. 2 is a block diagram showing one embodiment of the first luminance control unit 400 shown in FIG. 1.

[0049] Referring to FIG. 2, the first luminance control unit 400 in one embodiment includes an analog/digital converter 412, a counter 413, a converter processor 414, a register generation unit 415, a first selector 416, a second selector 417 and a gamma correction unit 418.

[0050] The analog/digital converter (hereinafter, referred to as an A/D converter) 412 compares an analog optical sensor signal (Ssens) outputted from the optical sensor 500 to a reference voltage (e.g., a predetermined reference voltage), and outputs a digital sensor signal (SD) corresponding to the reference voltage.

[0051] For example, in one embodiment, when the A/D converter 412 divides a surrounding brightness into four levels and outputs a 2-bit digital sensor signal (SD) according to the surrounding brightness, the A/D converter 412 may output a digital sensor signal (SD) of "11" in the brightest surrounding brightness level, and output a digital sensor signal (SD) of "10" in a relatively bright surrounding brightness level. Also, the A/D converter 412 may output a digital sensor signal (SD) of "01" in a relatively dark surrounding brightness level, and output a digital sensor signal (SD) of "00" in the darkest surrounding brightness level.

[0052] Also, the A/D converter 412 may further generate the selection signal (Ssel) for controlling ON/OFF of the second luminance control unit 600 and supply the generated selection signal (Ssel) to the second luminance control unit 600 in accordance with the analog optical sensor signal (Ssens).

[0053] More particularly, the A/D converter 412 may generate the selection signal (Ssel) for controlling the second luminance control unit 600 to be turned off if the analog optical sensor signal (Ssens) is sensed with a value less than a reference value (e.g., a predetermined set value), and generate the selection signal (Ssel) for controlling the second luminance control unit 600 to be turned on in other cases.

[0054] The description provided herein is just an exemplary embodiment for the purpose of illustration only, and is not intended to limit the scope of the invention.

[0055] For example, in other embodiments, the digital sensor signal (SD) outputted by the A/D converter 412 may be set to be the selection signal (Ssel), and ON/OFF of the second luminance control unit 600 may be controlled in accordance with the digital sensor signal (SD), or a separate converter, in addition to the A/D converter 412 for generating the digital sensor signal (SD), may be provided to generate the selection signal (Ssel).

[0056] The counter 413 counts a number (e.g., a predetermined number) of pulses (e.g., clock cycles of a clock signal (CLK)) during a certain time, for example during one frame period, by using a vertical synchronizing signal (Vsync) supplied from the outside, and outputs a counting signal (Cs) corresponding to the number (e.g., a predetermined number) of pulses.

[0057] For example, in the case of the counter 413 using a binary value having 2 bits, the counter 413 is reset to a value of '00' when the vertical synchronizing signal (Vsync) is inputted, and then the number to '11' may be counted by sequentially shifting a clock signal (CLK). In one embodiment, as those skilled in the art would appreciate, the clock signal (CLK) has a period (i.e., clock cycle) equal to $\frac{1}{4}$ of one frame of an image (e.g., a video image), such that the clock signal (CLK) is used by the counter 413 to count from '00' to '11' during one frame, and then, the counter 413 is re-set to a

reset state when the vertical synchronizing signal (Vsync) is inputted to the counter 413 again after one frame.

[0058] As in the above operation, the counter 413 sequentially counts the number from '00' to '11' and outputs a counting signal (Cs) corresponding to the counted number into the converter processor 414. This way, the counting signal (Cs) changes through '00', '01', '10' and '11' during one frame and back to '00' at the end of the frame in synchronization with the Vsync signal.

[0059] The converter processor 414 uses the digital sensor signal (SD) inputted from the A/D converter 412 and the counting signal (Cs) inputted from the counter 413 to output a control signal which will select a set value of each of the registers.

[0060] In other words, the converter processor 414 outputs a control signal corresponding to the digital sensor signal (SD) selected when the counting signal (Cs) outputted by the counter 413 is identical to the digital sensor signal (SD), and sustains the control signal until the next time when the digital sensor signal (SD) matches the counting signal (Cs). This way, the outputted control signal can be changed in the next frame when the digital sensor signal (SD) inputted from the A/D converter 412 is identical to the counting signal (Cs) inputted from the counter 413.

[0061] For example, if the ambient light is in the brightest state, then the converter processor 414 outputs a control signal (for example, a control signal set to 2-bit value such as '11') corresponding to the digital sensor signal (SD) of '11', and sustains the control signal until the digital sensor signal (SD) again matches the counting signal (Cs) outputted by the counter 413 according to the clock cycles (or pulses) of the clock signal (CLK). If the ambient light is in the darkest state, then the converter processor 414 outputs a control signal corresponding to the digital sensor signal (SD) of '00', and sustains the control signal until the digital sensor signal (SD) again matches the counting signal (Cs) outputted by the counter 413 according to the clock cycles (or pulses) of the clock signal (CLK). When the ambient light is in a relatively bright or dark state, the converter processor 414 outputs a control signal corresponding to the digital sensor signal (SD) of '10' or '01' and sustains the control signal until the next time when the digital sensor signal (SD) matches the counting signal (Cs) in the same manner as described above. In other embodiments, the control signal may be sustained during one or more frames or a partial frame using other methods as those skilled in the art would appreciate.

[0062] The register generation unit 415 divides a brightness of the ambient light into a plurality of brightness levels and stores a plurality of register set values corresponding to the brightness levels.

[0063] The first selection unit 416 selects register set values corresponding to the control signals, set by the converter processor 414, among the a plurality of the register set values stored in the register generation unit 415, and then outputs the selected register set values.

[0064] The second selection unit 417 may receive a 1-bit set value for controlling ON/OFF from the outside, and selectively control the brightness according to the ambient light by operating the first luminance control unit 400 if a value of '1' is selected as the 1-bit set value, and turning off the first luminance control unit 400 if a value of '0' is selected as the 1-bit set value. Hereinafter, the embodiment of the invention will be described in reference to a case where an operation of the first luminance control unit 400 is carried out. In this case,

the second selection unit **417** supplies the register set value, supplied from the first selection unit **416**, to the gamma correction unit **418**.

[0065] The gamma correction unit **418** generates a first luminance control signal (Vc1) which is a gamma correction signal corresponding to the register set values supplied from the second selection unit **417**. Here, the first luminance control signal (Vc1) has different values according to the brightness of the ambient light since the register set values supplied to the gamma correction unit **418** correspond to the optical sensor signal (Ssens) inputted from the optical sensor **500**. In one embodiment, the luminance of the display area is set so that it can be reduced if the gamma correction signal is a gamma correction signal corresponding to the darkest brightness level in the brightness of the ambient light. Such an operation is carried out in each of subpixels, for example, red (R), green (G) and blue (B) subpixels, respectively.

[0066] FIG. 3 is a diagram showing one exemplary embodiment of an A/D converter **412'**, which has some of the same functions as the A/D converter **412** shown in FIG. 2. The A/D converter **412'** that outputs the digital sensor signal (SD) corresponding to the analog optical sensor signal (Ssens) is shown in FIG. 3, but the present invention is not limited thereto. For example, the A/D converter **412** of FIG. 2 also includes a circuit for generating the selection signal (Ssel) corresponding to the analog optical sensor signal (Ssens).

[0067] Referring to FIG. 3, the A/D converter **412'** includes first, second and third selectors **21**, **22**, **23**, first, second and third comparators **24**, **25**, **26** and an adder **27**.

[0068] The first to third selectors **21**, **22**, **23** receive a plurality of gray level voltages distributed through a plurality of resistance arrays for generating a plurality of gray level voltages (VHI to VHO), and output the gray level voltages corresponding to differently set 2-bit values, which are referred to as reference voltages (VH, VM and VL).

[0069] The first comparator **24** compares the analog optical sensor signal (Ssens) with a first reference voltage (VH) and outputs the resultant value. For example, the first comparator **24** may output "1" if an analog optical sensor signal (Ssens) is higher than the first reference voltage (VH), and "0" if an analog optical sensor signal (Ssens) is lower than the first reference voltage (VH).

[0070] In the same manner, the second comparator **25** outputs a value obtained by comparing the analog optical sensor signal (Ssens) with a second reference voltage (VM), and the third comparator **26** outputs a value obtained by comparing the analog optical sensor signal (Ssens) with a third reference voltage (VL).

[0071] Also, a range of the analog optical sensor signal (Ssens) corresponding to the same digital sensor signal (SD) may be changed by varying the first to third reference voltages (VH to VL).

[0072] The adder **27** adds up all of the resultant values outputted from the first to third comparator **24**, **25**, **26** and outputs the values as a 2-bit digital sensor signal (SD).

[0073] Hereinafter, an operation of the A/D converter **412'** shown in FIG. 3 will be described in detail, assuming that the first reference voltage (VH) is set to 3V, the second reference voltage (VM) is set to 2V, the third reference voltage (VL) is set to 1V, and a voltage value of the analog optical sensor signal (Ssens) is increased as the ambient light becomes brighter.

[0074] If the analog optical sensor signal (Ssens) has a lower voltage than 1V, then all of the first to third comparators

24, **25**, **26** output '0', and therefore the adder **27** outputs a digital sensor signal (SD) of '00'.

[0075] Also, if the analog optical sensor signal (Ssens) has a voltage between 1V and 2V, then the first to third comparators **24**, **25**, **26** output '0', '0', '1' respectively, and therefore the adder **27** outputs a digital sensor signal (SD) of '01'.

[0076] In the same manner, if the analog optical sensor signal (Ssens) has a voltage between 2V and 3V, then the adder **27** outputs a digital sensor signal (SD) of '10', and if the analog optical sensor signal (Ssens) has a higher voltage than 3V or more, then the adder **27** outputs a digital sensor signal (SD) of '11'.

[0077] The A/D converter **412'** divides a brightness of the ambient light into four brightness levels while being driven in the above-mentioned manner, and then outputs '00' in the darkest brightness level, outputs '01' in a relatively dark brightness level, outputs '10' in a relatively bright brightness level, and outputs '11' in the brightest brightness level.

[0078] FIG. 4 is a diagram showing one exemplary embodiment of a gamma correction unit shown in FIG. 2.

[0079] Referring to FIG. 4, the gamma correction unit **418** includes a ladder resistor **61**, an amplitude control register **62**, a curve control register **63**, a maximum voltage selector **64**, a minimum voltage selector **65**, first, second, third and fourth intermediate voltage selectors **66**, **67**, **68** and **69**, and a gray level voltage amplifier **70**.

[0080] The ladder resistor **61** sets the highest level voltage (VHI) supplied from the outside, as a reference voltage, and includes a plurality of variable resistors connected in series between the lowest level voltage (VLO) and the reference voltage (VHI). In this case, a plurality of gray level voltages are generated through the ladder resistor **61**.

[0081] On one hand, if the ladder resistor **61** is set to a low value, amplitude modulation range becomes narrow but its modulation accuracy is improved. On the other hand, if the ladder resistor **61** is set to a high value, amplitude modulation range becomes wide but its modulation accuracy is deteriorated.

[0082] The amplitude control register **62** supplies size data to the maximum voltage selector **64** and the minimum voltage selector **65**, respectively. The size data determines the sizes of the highest gray level voltage and the lowest gray level voltage.

[0083] For example, the amplitude control register **62** may receive an upper 10-bit value among the register set values, and then output the uppermost (or most significant) 3-bit register set values into the maximum voltage selector **64** and output 7-bit register set values to the minimum voltage selector **65**. At this time, the number of gray levels to be selected may be increased by increasing the set bit number and a gray level voltage may be differently selected by varying the register set values.

[0084] The maximum voltage selector **64** selects a gray level voltage corresponding to the 3-bit register set values, supplied from the amplitude control register, among a plurality of the gray level voltages distributed through the ladder resistor **61**, and then outputs the selected gray level voltage as the highest voltage (V0) for displaying the lowest gray levels.

[0085] The minimum voltage selector **65** selects a gray level voltage corresponding to the 7-bit register set values, supplied from the amplitude control register, among a plurality of the gray level voltages distributed through the ladder

resistor **61**, and then outputs the selected gray level voltage as the lowest voltage (**V63**) for displaying the highest gray levels.

[0086] The curve control register **63** outputs gamma data into a plurality of intermediate voltage selectors **66**, **67**, **68** and **69**, respectively, the gamma data being capable of improving or optimizing display characteristics of the display area **100**.

[0087] For example, the curve control register **63** may receive a lower 16-bit value among the register set values, and output a 4-bit register set value into the first to fourth intermediate voltage selectors **66** to **69**, respectively. At this time, the register set value may be varied, and the gray level voltage, which may be selected according to the register set value, may be also adjusted.

[0088] Here, the upper 10-bit values among the register values generated in the register generation unit **415** are inputted into the amplitude control register **62**, and the lower 16-bit values are inputted into the curve control register **63**, and then the upper 10-bit values and the lower 16-bit values are selected as the register set values.

[0089] The first to fourth intermediate voltage selectors **66** to **69** select intermediate voltages corresponding to inflection points whose inclination is changed in a gamma curve showing a relation of the gamma-corrected gray level voltages corresponding to gray levels so as to correspond to the register set values supplied from the curve control register **63**. Accordingly, the number of the intermediate voltage selectors **66** to **69** is set to be the same as the number of the inflection points in the gamma curve showing the optimum display characteristics of the display area **100**.

[0090] More particularly, the first intermediate voltage selector **66** distributes a voltage between the gray level voltage outputted from the maximum voltage selector **64** and the gray level voltage outputted from the minimum voltage selector **65** using a plurality of resistance arrays, and then selects and outputs the gray level voltages corresponding to the 4-bit register set values.

[0091] The second intermediate voltage selector **67** distributes a voltage between the gray level voltage outputted from the maximum voltage selector **64** and the gray level voltage outputted from the first intermediate voltage selector **66** using a plurality of resistance arrays, and then selects and outputs the gray level voltages corresponding to the 4-bit register set values.

[0092] The third intermediate voltage selector **68** distributes a voltage between the gray level voltage outputted from the maximum voltage selector **64** and the gray level voltage outputted from the second intermediate voltage selector **67** using a plurality of resistance arrays, and then selects and outputs the gray level voltages corresponding to the 4-bit register set values.

[0093] The fourth intermediate voltage selector **69** distributes a voltage between the gray level voltage outputted from the maximum voltage selector **64** and the gray level voltage outputted from the third intermediate voltage selector **68** using a plurality of resistance arrays, and then selects and outputs the gray level voltages corresponding to the 4-bit register set values.

[0094] In the operation as described above, it is possible to adjust a curve of the intermediate gray level unit according to the register set values of the curve control register **63**, and therefore a gamma characteristic may be easily adjusted, depending on the characteristic of each of light emitting ele-

ments. Also, in order to bulge the gamma curve characteristic downward, a resistor value of the ladder resistor **61** is set so that an electric potential difference between the gray levels can be increased as a low gray level is displayed, while a resistor value of the ladder resistor **61** is set so that an electric potential difference between the gray levels can be decreased as a low gray level is displayed so as to bulge the gamma curve characteristic upward.

[0095] The gray level voltage amplifier **70** outputs a plurality of gray level voltages corresponding to a plurality of gray levels displayed in the display area **100**, respectively. For the sake of convenience, an output of the gray level voltage corresponding to 64 gray levels is shown in FIG. 4. However, the present invention is not limited thereto.

[0096] More particularly, the gray level voltage amplifier **70** receives intermediate voltages from the plurality of the intermediate voltage selectors **66** to **69**, generates a plurality of voltage levels as the gray level voltages and outputs each of the gray level voltages, wherein a plurality of the voltage levels have a linear relation within two intermediate voltage ranges and the gray level voltages may display all of the gray levels. In one embodiment, the gray level voltage amplifier **70** is composed of a plurality of resistors having the same resistance and connected in series. However, the present invention is not limited thereto.

[0097] The above operation is carried out so that red (R), green (G), blue (B) subpixels can obtain substantially the same luminance characteristic, considering the changes in their own characteristics of red (R), green (G), blue (B) light-emitting elements. For this purpose, the amplitude and the curve may be differently set in the red (R), green (G), blue (B) subpixels through the amplitude control register **62** and the curve control register **63** by installing the gamma correction unit **418** in every red (R), green (G), blue (B) subpixel groups.

[0098] FIG. 5A and FIG. 5B are graphs showing a gamma curve according to the gamma correction circuit **418** shown in FIG. 4.

[0099] FIG. 5A shows that the highest voltage for displaying the lowest gray level is not changed, and amplitude of the lowest voltage for displaying the highest gray level may be adjusted according to the 7-bit register set value outputted by the amplitude control register **62**. Here, an OFF voltage (V_{off}) is a voltage corresponding to a black gray level (a gray level value of 0), and an ON voltage (V_{on}) is a voltage corresponding to a white gray level (a gray level value of 63).

[0100] A reference numeral **A1** represents a gamma curve corresponding to the digital sensor signal (SD) when the surrounding brightness is in the darkest state, and a reference numeral **A2** represents a gamma curve corresponding to the digital sensor signal (SD) when the surrounding brightness is in a relatively dark state. Also, a reference numeral **A3** represents a gamma curve corresponding to the digital sensor signal (SD) when the surrounding brightness is in a relatively bright state, and a reference numeral **A4** represents a gamma curve corresponding to the digital sensor signal (SD) when the surrounding brightness is in the brightest state. In the gamma curves **A1**, **A2**, **A3** and **A4**, an off voltage V_{off} corresponds to a black gray scale level (i.e., gray level value of 0) and on voltages V_{on1} , V_{on2} , V_{on3} and V_{on4} , respectively, correspond to a white gray scale level (i.e., gray level value of 63).

[0101] In one embodiment, in order to reduce the amplitude range of the gray level voltage, the minimum voltage selector **65** is set to select the highest voltage level by adjusting a

register set value of the amplitude control register **62**. Also, in order to increase the amplitude range of the gray level voltage, the minimum voltage selector **65** is set to select the lowest voltage level.

[0102] FIG. 5B shows that a gamma curve is adjusted by changing an intermediate level of the gray level voltage according to the register set values supplied by the register curve control register **63**, without changing the highest voltage for displaying the lowest gray level and the lowest voltage for displaying the highest gray level.

[0103] The 4-bit register set values are respectively inputted into the first to fourth intermediate voltage selectors **66** to **69**, and four gamma values corresponding to the register set values are selected to generate a gamma curve. As can be seen in FIG. 5B, the change in inclination of a C2 curve is higher than the change in inclination of a C1 curve and lower than the change in inclination of a C3 curve.

[0104] As shown in FIG. 5A and FIG. 5B, the gray level voltages are changed to form a gamma curve by changing a set value of the gamma control register. Accordingly, it has been illustrated that brightness of each of the pixels **110** in the display area **100** may be adjusted.

[0105] FIG. 6 is a block diagram showing one exemplary embodiment of the second luminance control unit **600** shown in FIG. 1.

[0106] Referring to FIG. 6, the second luminance control unit **600** includes a switch unit **610**, a data sum-up unit **620**, a controller **630**, a lookup table **635** and a second luminance control signal (Vc2) generation unit **640**.

[0107] The switch unit **610** controls whether or not control signals such as a synchronizing signal (Vsync) and a clock signal (CLK), and data (RGB Data) of one frame are supplied to the data sum-up unit **620** in accordance with the selection signal (Ssel) supplied by the first luminance control unit **400**. In one embodiment, the clock signal (CLK) inputted into the second luminance control unit **600** is identical to the clock signal (CLK) inputted into the first luminance control unit **400**. In other embodiments, the clock signals (CLK) may be similar or different.

[0108] By way of example, the switch unit **610** supplies the control signals such as the synchronizing signal (Vsync) and the clock signal (CLK), and the data (RGB Data) of one frame to the data sum-up unit **620** when the selection signal (Ssel) directing ON of the second luminance control unit **600** is inputted. Further, the switch unit **610** interrupts the supply of the control signals such as the synchronizing signal (Vsync) and the clock signal (CLK), and the data (RGB Data) of one frame to the data sum-up unit **620** in the other case, that is, when the selection signal (Ssel) directing OFF of the second luminance control unit **600** is inputted.

[0109] The data sum-up unit **620** generates sum-up data obtained by adding up image data (RGB Data) inputted during one frame period, and generates control data having at least two bits including the uppermost bits (i.e., the most significant bits) of the sum-up data. Hereinafter, it will be assumed that an upper (i.e., most significant) 5-bit value of the sum-up data is set to the control data for the sake of convenience. Here, a high value of the sum-up data means that the image data includes a large amount of data having a high luminance more than a reference luminance (e.g., a predetermined luminance), and a low value of the sum-up data means that the image data includes a small amount of data having a high luminance more than the reference luminance (e.g., the

predetermined luminance). The control data generated in the data sum-up unit **620** is transmitted to the second controller **630**.

[0110] The lookup table **635** stores a width (EW) information of the light emission control signal corresponding to the control data (for example, control data from 0 to 31 if the control data is set to a 5-bit value). Here, the width (EW) of the light emission control signal is a data value having information on the width of the light emission control signal for controlling a light emission time of the pixels **110**, and the width (EW) of the light emission control signal stored in the lookup table **635** is set so that the luminance of the display area **100** can be reduced with an increasing value of the control data. That is to say, the width (EW) of the light emission control signal is set to limit an amount of electric current flowing to the display area **100** by reducing a light emission time of the pixels **110** as the value of the control data increases.

[0111] The controller **630** extracts from the lookup table **635** the width (EW) information of the light emission control signal that corresponds to the control data supplied from the data sum-up unit **620**, and transmits the extracted width (EW) information to the second luminance control signal (Vc2) generation unit **640**.

[0112] The second luminance control signal (Vc2) generation unit **640** generates a second luminance control signal (Vc2) corresponding to the width (EW) information of the light emission control signal supplied from the controller **630**, and outputs the generated second luminance control signal (Vc2) to the scan driver **200**.

[0113] FIG. 7 is a block diagram showing one exemplary embodiment of the lookup table **635** shown in FIG. 6. The lookup table **635** shown in FIG. 7 is based on an assumption that the amount of time that an electric current flows to the pixel **110** increases as the width (EW) of the light emission control signal increases, but the description provided herein is not intended to limit the scope of the invention. In practice, the content stored in the lookup table **635** may be varied depending on the configuration of the pixel circuits, the resolution and size of the display area **100**, etc., as those skilled in the art would appreciate.

[0114] Referring to FIG. 7, the width (EW) of the light emission control signal corresponding to an upper 5-bit value (namely, the control data) of the sum-up data is stored in the lookup table **635**. Here, the width (EW) of the light emission control signal is set so that it can be narrowed with an increasing value of the control data so as to limit a power consumption within a constant range (in other words, to limit luminance). Here, if the control data has at least one value including the minimum value, then the width (EW) of the light emission control signal is sustained at a constant width.

[0115] By way of example, if the control data is set to a value of '4' or less, the width (EW) of the light emission control signal is set to a width corresponding to 325 cycles of a horizontal synchronizing signal (Hsync) so as not to limit the luminance. As described above, when the control data has at least one value including the minimum value, if the width (EW) of the light emission control signal is not limited, a contrast ratio may be improved when a dark image is displayed, and therefore an image having an improved contrast may be displayed.

[0116] If the control data is set to a value of '5' or more, then the width (EW) of the light emission control signal is slowly narrowed with an increasing value of the control data. As

described above, if the control data has a higher value than at least one value including the minimum value, then the power consumption may be sustained within a constant range since the luminance is lowered as the width (EW) of the light emission control signal gets narrow. Also, eye fatigue may be alleviated due to the limited luminance of the display area **100** even if one watches images for a long time. Actually, a ratio for limiting the luminance is increased since the increased number of pixels displaying high gray levels increases the value of the control data.

[0117] In order to prevent the excessive reduction of the luminance, a maximum limitation ratio for the luminance is defined, and therefore the pixels **110** displaying high gray levels are set to have a light emitting ratio of 34% or less even if these pixels **110** having high gray levels take a majority of an area of the display area **100**. In other words, if the control data has a higher value than at least one value including the minimum value, then the width (EW) of the light emission control signal should not be set to a width less than a reference width (e.g., a predetermined width). In one embodiment, the lookup table **635** is applied to a moving image. In one embodiment, if an image displayed in the organic light emitting display device includes a still image and a moving image, the limited range of the luminance is varied according to kinds of the image. For example, in one embodiment, the maximum limitation ratio of the luminance may reach 50% in the case of the still image.

[0118] As described above, the organic light emitting display device in exemplary embodiments according to the present invention may be useful in preventing an excessive electric current from flowing to the display area and in reducing a power consumption by controlling a luminance of the display area in accordance with the brightness of the ambient light and the data of one frame, as well as solving the problem that the visibility is varied according to the surrounding brightness.

[0119] Also, if the luminance of the display area is maximally limited by using the first luminance control unit, then the excessive reduction in the luminance may be prevented by setting (or configuring) the first luminance control unit to turn off the second luminance control unit. For example, the excessive reduction in the luminance may be prevented in the darkest brightness level of the ambient light by turning off the second luminance control unit if the brightness of the display area is maximally limited by using the first luminance control signal generated in the first luminance control unit. In this case, it is possible to prevent unnecessary power consumption and the reduction to the safety margin for memory operation, caused by the operation of the second luminance control unit.

[0120] The description provided herein is just exemplary embodiments for the purpose of illustrations only, and not intended to limit the scope of the invention, so it should be understood that other equivalents and modifications could be made thereto without departing from the spirit and scope of the invention as those skilled in the art would appreciate. Therefore, it should be understood that the present invention has a scope that is defined in the claims and their equivalents.

What is claimed is:

1. An organic light emitting display device for displaying an image, the organic light emitting display device having a plurality of scan lines, a plurality of light emission control lines and a plurality of data lines, and comprising:

a display area including a plurality of pixels coupled to the scan lines, the light emission control lines and the data lines;

a scan driver electrically coupled to the display area through the scan lines and the light emission control lines;

a data driver electrically coupled to the display area through the data lines;

an optical sensor for generating an optical sensor signal corresponding to a brightness of an ambient light;

a first luminance control unit for outputting a first luminance control signal for controlling a gamma-corrected gray level voltage of a data signal of the image, applied to the data lines, in accordance with the optical sensor signal; and

a second luminance control unit for outputting a second luminance control signal for controlling a width of a light emission control signal applied to the light emission control lines, in accordance with data of one frame of the image,

wherein the first luminance control unit is adapted to control the second luminance control unit to be turned on and off.

2. The organic light emitting display device according to claim **1**, wherein the first luminance control unit is further adapted to generate a selection signal for controlling on and off of the second luminance control unit in accordance with the optical sensor signal.

3. The organic light emitting display device according to claim **2**, wherein the selection signal turns off the second luminance control unit in accordance with the optical sensor signal corresponding to at least one brightness level including a darkest brightness level of the ambient light.

4. The organic light emitting display device according to claim **1**, wherein the first luminance control unit comprises:

an analog/digital converter for converting the optical sensor signal, which is an analog signal, to a digital sensor signal;

a counter for counting pulses to generate a counting signal during one frame period;

a converter processor for outputting a control signal corresponding to the digital sensor signal and the counting signal;

a register generation unit for dividing the brightness of the ambient light into a plurality of brightness levels and storing a plurality of register set values corresponding to the brightness levels;

a selection unit for selecting one register set value corresponding to the control signal outputted by the converter processor, among the plurality of register set values stored in the register generation unit, and outputting the selected one register set value; and

a gamma correction unit for generating the first luminance control signal, which is a gamma correction signal, corresponding to the selected one register set value supplied by the selection unit.

5. The organic light emitting display device according to claim **4**, wherein the analog/digital converter is adapted to generate a selection signal for controlling on and off of the second luminance control unit in accordance with the optical sensor signal.

6. The organic light emitting display device according to claim **4**, wherein the gamma correction signal is set to

increasingly reduce a luminance of the display area as the brightness of the ambient light decreases.

7. The organic light emitting display device according to claim 1, wherein the second luminance control unit comprises:

- a data sum-up unit for summing up the data of one frame to generate sum-up data and generating control data having at least two bits including most significant bits of the sum-up data;
- a lookup table for storing a width information of the light emission control signal corresponding to the control data;
- a controller for extracting the width information of the light emission control signal corresponding to the control data from the lookup table; and
- a luminance control signal generation unit for generating the second luminance control signal corresponding to the width information of the light emission control signal supplied by the controller.

8. The organic light emitting display device according to claim 7, wherein the width of the light emission control signal is set so that a luminance of the display area is decreased as a value of the control data increases.

9. The organic light emitting display device according to claim 7, wherein the second luminance control unit further comprises a switch unit for selectively providing the data of one frame to the data sum-up unit in accordance with a selection signal supplied by the first luminance control unit.

10. A method for driving an organic light emitting display device having a display area including a plurality of pixels coupled to a plurality of scan lines, a plurality of light emission control lines and a plurality of data lines, the method comprising:

- generating an optical sensor signal corresponding to a brightness of an ambient light;
- generating a luminance control signal for controlling a gamma-corrected gray level voltage of a data signal of the image, applied to the data lines, in accordance with the optical sensor signal;
- controlling a luminance of the display area by using the data signal in accordance with the luminance control signal; and
- generating a selection signal in accordance with the optical sensor signal.

11. The method for driving an organic light emitting display device according to claim 10, wherein said generating a luminance control signal comprises:

- converting the optical sensor signal to a digital sensor signal;
- counting pulses to generate a counting signal during one frame period;
- outputting a control signal in accordance with the digital sensor signal and the counting signal;
- selecting one register set value corresponding to the control signal among the previously set register set values and outputting the selected register set value; and

generating the luminance control signal corresponding to the one register set value.

12. The method of claim 10, wherein the luminance control signal is a gamma correction signal.

13. The method for driving an organic light emitting display device according to claim 10, further comprising controlling a width of a light emission control signal applied to the light emission control lines, in accordance with the selection signal.

14. The method for driving an organic light emitting display device according to claim 13, wherein said controlling a width of the light emission control signal comprises:

- generating sum-up data obtained by adding up the data of one frame in accordance with the selection signal; and
- generating a second luminance control signal for controlling the width of the light emission control signal in accordance with the sum-up data.

15. An organic light emitting display device for displaying an image, the organic light emitting display device having a plurality of scan lines, a plurality of light emission control lines and a plurality of data lines, and comprising:

- a display area including a plurality of pixels coupled to the scan lines, the light emission control lines and the data lines;
- a scan driver electrically coupled to the display area through the scan lines and the light emission control lines;
- a data driver electrically coupled to the display area through the data lines;
- an optical sensor for generating an optical sensor signal corresponding to a brightness of an ambient light;
- a first luminance control unit for adjusting a brightness of an image in accordance with the optical sensor signal; and
- a second luminance control unit for adjusting the brightness of the image according to gray levels of data representing the image, wherein an operation of the second luminance control unit is controlled by the first luminance control unit.

16. The organic light emitting display device of claim 15, wherein the second luminance control unit is turned off or on in accordance with a select signal provided by the first luminance control unit.

17. The organic light emitting display device of claim 16, wherein the second luminance control unit is turned off when the ambient light has a brightness below a reference brightness level.

18. The organic light emitting display device of claim 15, wherein the first luminance control unit provides to the data driver a control signal for controlling a gamma-corrected gray level voltage of a data signal applied to the data lines.

19. The organic light emitting display device of claim 15, wherein the second luminance control unit provides to the scan driver a control signal for controlling a width of a light emission control signal applied to the light emission control lines.

* * * * *

专利名称(译)	有机发光显示装置及其驱动方法		
公开(公告)号	US20080186264A1	公开(公告)日	2008-08-07
申请号	US11/861128	申请日	2007-09-25
[标]申请(专利权)人(译)	李旭		
申请(专利权)人(译)	李旭		
当前申请(专利权)人(译)	李旭		
[标]发明人	LEE WOOK		
发明人	LEE, WOOK		
IPC分类号	G09G3/32		
CPC分类号	G09G3/3233 G09G2310/027 G09G2320/0613 G09G2320/0626 G09G2360/16 G09G2330/021 G09G2330/045 G09G2360/144 G09G2320/0673		
优先权	1020070011785 2007-02-05 KR		
其他公开文献	US8022902		
外部链接	Espacenet USPTO		

摘要(译)

一种有机发光显示装置，包括：显示区域，包括与扫描，发光控制和数据线耦合的多个像素；扫描驱动器通过扫描线和发光控制线电耦合到显示区域；数据驱动器通过数据线电耦合到显示区域；光学传感器，用于产生对应于环境光亮度的光学传感器信号；第一亮度控制单元，用于根据光学传感器信号输出用于控制数据信号的经伽马校正的灰度级电压的第一亮度控制信号，以及用于输出用于控制宽度的第二亮度控制信号的第二亮度控制单元根据图像的一帧数据的发光控制信号。第一亮度控制单元接通和断开第二亮度控制单元。

